

SONANCE

VISUAL EXPERIENCE DATA SHEET

VX66R SST

TECHNICAL SPECIFICATIONS

SKU	VX66R SST 93684 - Each
Tweeter	1" (25mm) ceramic dome, Ferrofluid-cooled, acoustic back chamber, dual voice coil
Woofer	6.5" (165mm) Kevlar/Nomex cone, rubber surround, pivoting, dual voice coil
Dispersion Technology	Sinusoidal textured waveguide
Speaker Pivot	Coincident woofer and tweeter, +/-13° pivot
Frequency Response	43Hz - 20kHz +/-3dB
Impedance	8 ohms nominal; 6 ohms minimum
Power Handling (RMS)	5 watts minimum; 140 watts maximum
Sensitivity (2.83V/1m)	90dB SPL
Round Micro Trim Grille (Dia)	9.62" (244.4mm)
Round Trimless Grille (Dia)	9.28" (235.6mm)
Square Micro Trim Grille (WxH)	9.62" x 9.62" (244.4mm x 244.4mm)
Square Trimless Grille (WxH)	9.28" x 9.28" (235.6mm x 235.6mm)
Speaker Mounting Depth (D)	4.92" (125mm)
Mounting Depth + Retrofit Encl.	5.75" (146.1mm)
Cut-Out Dims (Dia)	8.25" (210mm)
Shipping Weight	4.5 lbs. (2.1kg)

DIMENSIONAL DRAWINGS

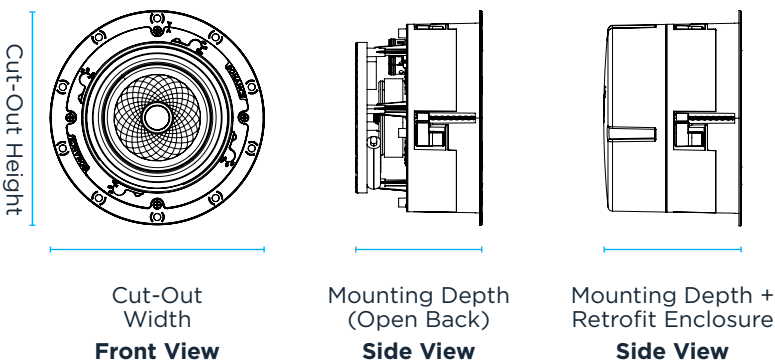

VX 6" ROUND ACCESSORIES

VX6R-GRILLE-T 6" Micro Trim Round Grille / Pair	93575
VX6R-GRILLE-NT 6" Trimless Round Grille / Pair	93576
VX6SQ-T 6" Micro Trim Square Adapter / Pair	96030
VX6SQ-T-5PR 6" Micro Trim Square Adapter / 5xPair	96033
VX6SQ-NT 6" Trimless Square Adapter / Pair	93586
VX6SQ-NT-5PR 6" Trimless Square Adapter / 5xPair	93589
VX6-ENCL-R 6" Round Enclosure / Pair	96343
FLEXBRK-6-R 6" Round Flex Bracket / 5x Pair	92337

LIMITED LIFETIME WARRANTY

Sonance warrants to the first end-user purchaser that this Sonance-brand product ("Product"), when purchased from an authorized Sonance Dealer/Distributor, will be free from defective workmanship and materials for the life of the Product, except for the grille, which is warranted for five (5) years. Sonance will at its option and expense either repair the defect or replace the Product with a new or remanufactured Product or a reasonable equivalent. ©2024 Sonance. All rights reserved. Sonance is a registered trademarks of Dana Innovations. Due to continuous product improvement, all features and specifications are subject to change without notice. For the latest Sonance product specification information visit our website at www.sonance.com. 991 Calle Amanecer • San Clemente, CA 92673 USA • Phone: (949) 492-7777 • Fax: (949) 361-5151 • Technical Support: (949) 492-7777 12.16.2024